

TECHNICAL DRAWING

UV Fused Silica Step Window

Part Number: STW-18515

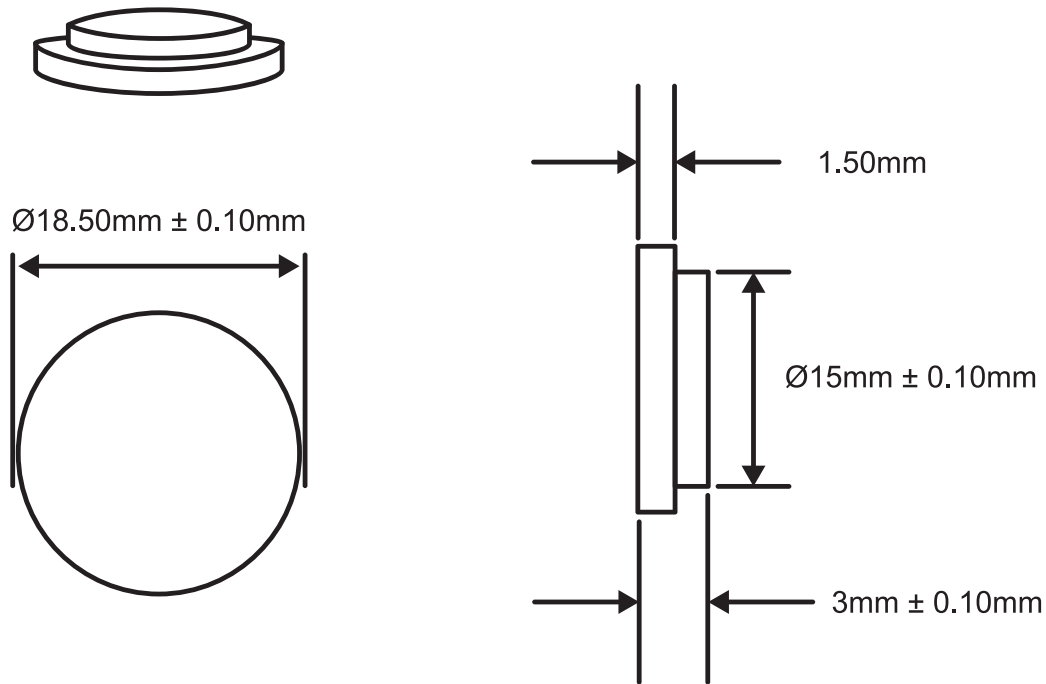

Specification:

Material:	UV Fused Silica - Spectrosil 2000® or Corning 7980
Edges & Step:	Fine ground
Two Faces:	Polished 60/40
Edges Chamfered:	0.20mm @45° nom